

# BXL<sup>®</sup>

## ROTARY CONTROL VALVE



**VALTEK**<sup>TM</sup>  
**SULAMERICANA**

# INTRODUCTION

The BXL control valve is a high performance eccentric disc rotary valve, developed for fluid control on industrial processes, that combine usually high flow rates and low or medium differential pressures.

In addition to allowing accurate fluid control on several disc openings, the exclusive geometry of the BXL disc associated with its double eccentricity, assures a great functioning smoothness and an excellent sealing capacity for long periods.

The BXL valve was designed to withstand differential pressures up to 725 psi (50 Bar) and operating temperatures from -40 to 600 °F (-40 to 315 °C).

Available in sizes from 2 to 12 inches with Wafer or Lug style bodies, the BXL valve can be produced in a wide variety of materials such as carbon steel, stainless steel and special alloys with ANSI classes 150 – 300 or DIN PN 16 – 40.

Its advanced engineering design, with non-selective discs and shafts considerably reduces operating costs and simplifies maintenance tasks, while the extra deep packing box with excellent internal finish, allows the utilization of all Valtek Sulamericana packing options available, including special versions for fugitive emissions control.

The combination of the enhanced design of high performance eccentric disc valve, precise and reliable, with the rotary actuators Series RA-XL makes the BXL an exceptional cost-effective choice for those control applications with ANSI ratings 150 and 300.

**BODY SUB-ASSEMBLY (FIGURE 1)**

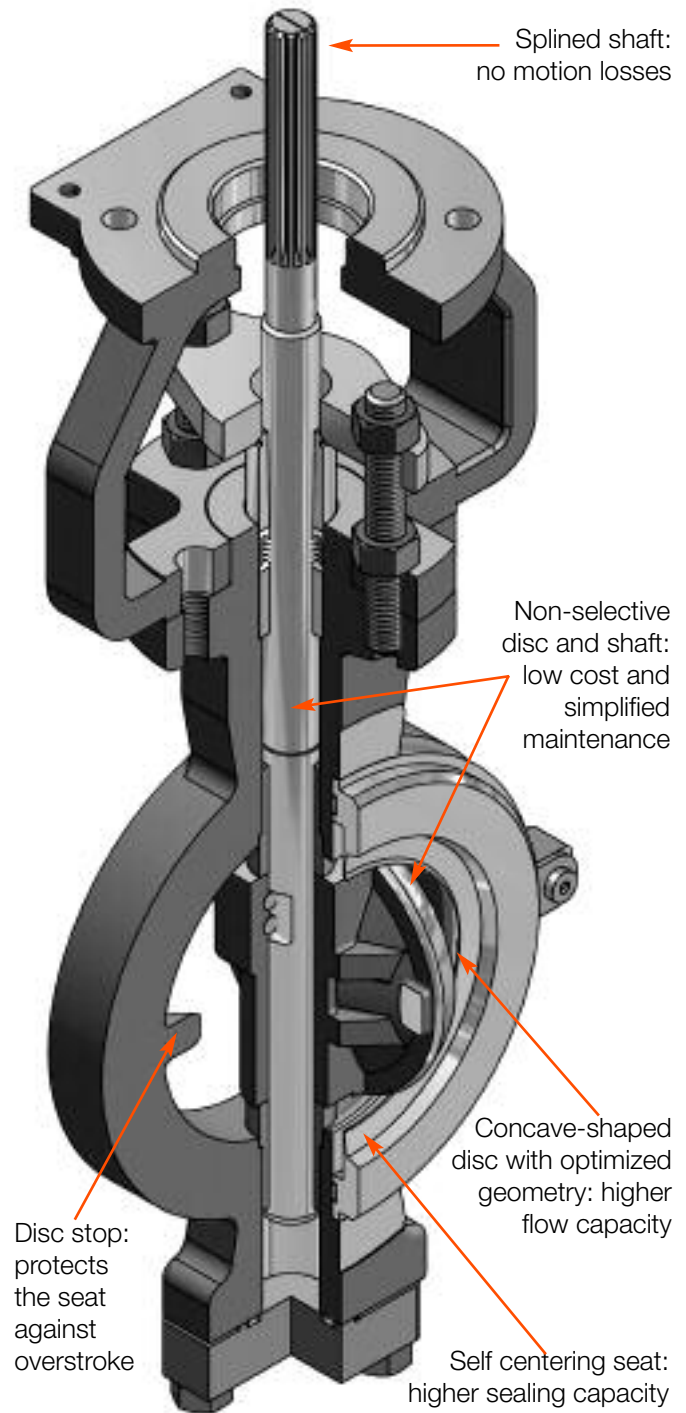

**Rangeability higher than 100:1**

**ANSI Class IV Shutoff – Metal Seat**  
**ANSI Class VI Shutoff – Soft Seat**

**ECCENTRIC DISC ROTATION (FIGURE 2)**

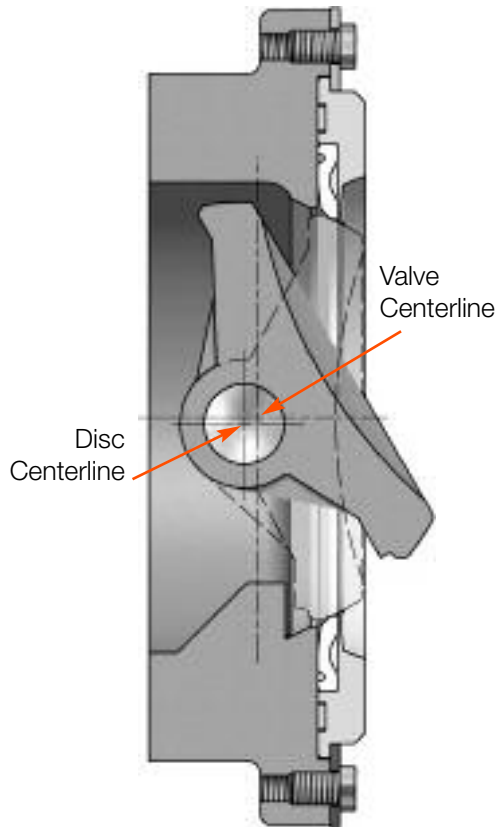

**SOFT SEAT - SEATING PRINCIPLE (FIGURE 3)**

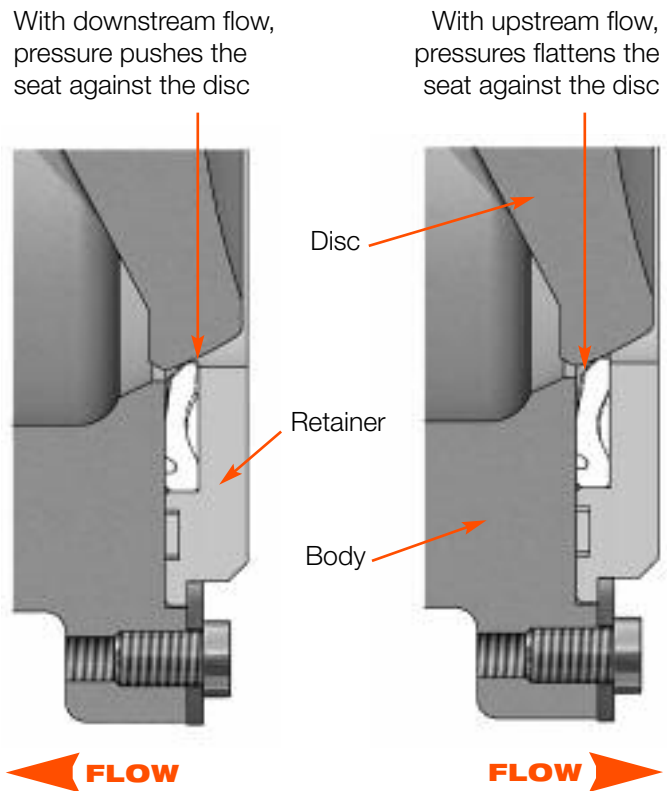

**Reliability**

The double eccentricity feature, typical of the high performance BXL valve design (Fig. 2) makes the disc move out from the seat immediately at the first rotation angles of the actuator, which extends the life of the trim, preserves the valve sealing capacity, and reduces maintenance interventions and operational costs.

Additionally, the BXL design uses a pressure-assisted seating principle which, in addition to assuring an excellent level of bi-directional sealing, contributes to reduce the valve breakout torque, at low or significant differential pressures, thus reducing the need of oversized actuators. The fluid pressure press the valve seat against the disc on both flow directions (Fig. 3) making the valve able to operate, depending on process conditions, either with upstream flow (tending to close), downstream flow (tending to open) or in applications with alternate flows. This operating principle assures a tightness capacity through the valve directly proportional to the differential pressure increase.

When supplied with metal seat, the BXL valve reaches tightness levels above those required by ANSI B16.104/FCI-70.2 Class IV and, when equipped with soft seats, meets the Class VI requirements of this same standard. The combination of its low breakout torque with the optimized geometry of the disc, the rugged shaft made from 17-4PH stainless steel as standard material and bearings with broad support surfaces contribute to the superior control performance of the BXL valve, even in applications under higher differential pressures.

These characteristics, together with the use of: spring-cylinder actuators with proven lifetime longer than a million of cycles, HPP1500 Analog or HPP3000 and HPP3500 Digital Positioners, which provide an accurate and refined process control; Packing boxes with large depth that meet the EPA\* requirements; splined driving shaft with no motion losses, make the BXL one of the most modern, advanced and accurate eccentric disc control valve in the world market.

\*EPA = U. S. Environmental Protection Agency

## SEAT CONFIGURATIONS (TABLE I)

The BXL control valve can be provided with several seat configurations, according to the application they are intended for. For liquid services all valves must be assembled with the shaft downstream the flow direction, irrespective of the failsafe position. For gas services, the flow direction must be in according to the specified failsafe position, i.e., normally open valves must be installed with shaft downstream the flow direction and, normally closed valves must be installed with shaft upstream the flow direction.

### SOFT SEAT

This system is comprised by a polymer seat, usually virgin PTFE or glass filled PTFE, with a configuration that allows excellent sealing levels.

Description	Shaft orientation	Shutoff Class
One soft seat plus one seat retainer	Downstream	VI
	Upstream	VI

### METAL SEAT

Metal seats are used in applications where operating temperatures exceed the soft seat limits.

Description	Shaft orientation	Shutoff Class
One metal seat	Downstream	IV
	Upstream	IV

### DUAL SEAT

This system is comprised by a soft seat and a metal seat that provides an extra sealing.

Description	Shaft orientation	Shutoff Class
One soft seat plus one metal seat	Downstream	IV
	Upstream	IV

Note: contact Valtek Sulamericana Application Engineering to assist in flow direction selection on special applications.

### SOFT SEAT (FIGURE 4)

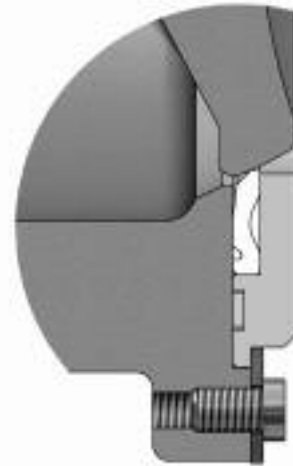

### METAL SEAT (FIGURE 5)

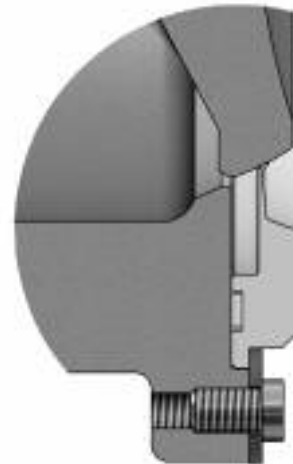

### DUAL SEAT (FIGURE 6)

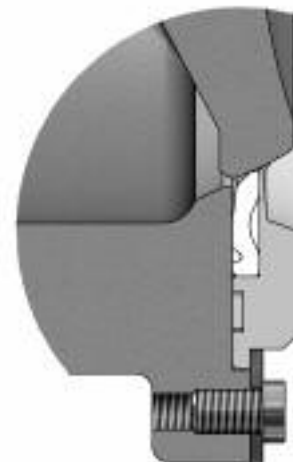

# SPECIFICATIONS

## Pressure Recovery Factor, FL

The liquid pressure recovery factor, FL, indicates the amount of pressure that will be recovered between the “vena contracta” point and the valve outlet. It takes into account the influence of the valve internal geometry on the maximum capacity of the valve and the tendency that the valve presents to operate with cavitation or choked flow. Smaller FL values indicate that the valve will cavitate earlier.

Figure below compares the FL values of a BXL with a typical butterfly valve. The BXL FL values are between a typical butterfly and globe valve values. So, the tendency to cavitate or choke will be more than a globe valve, but less than a typical butterfly valve.

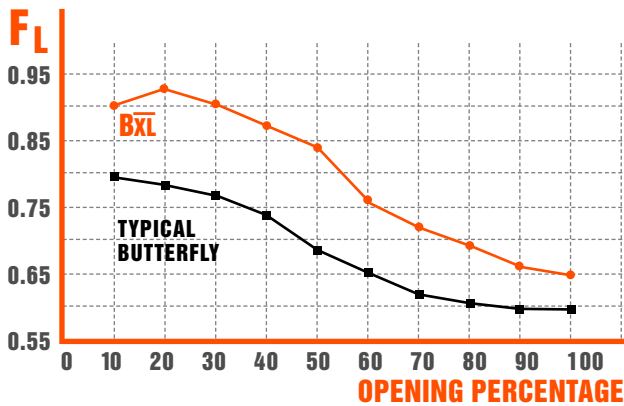

**PRESSURE AND TEMPERATURE LIMITS FOR GASKETS (TABLE II)**

GASKET MATERIAL	PRESSURE		TEMPERATURE	
	Psi	Bar	°F	°C
PTFE	725	50	350	176
316 SS/Graphite	725	50	600	315

**BODY SPECIFICATIONS (TABLE III)**

<b>Sizes (inches)</b>	2; 3; 4; 6; 8; 10; 12
<b>Body style</b>	<ul style="list-style-type: none"> <li>■ Wafer</li> <li>■ Lug</li> </ul>
<b>Face Finish</b>	125-250 Ra Standard
<b>Rating</b>	<ul style="list-style-type: none"> <li>■ ANSI Class 150-300</li> <li>■ DIN PN 16 - 40*</li> </ul>
<b>Shutoff</b>	<ul style="list-style-type: none"> <li>■ ANSI Class IV with Metal Seat</li> <li>■ ANSI Class VI with soft seat</li> </ul>
<b>Operating Temperature</b>	-20 to 600°F (-28 to 315°C)

\*Depending on body size and style.

**TEMPERATURE LIMITS FOR PACKINGS (TABLE IV)**

MATERIAL	TEMPERATURE*	
	°F	°C
PTFE V-Rings	-20 to 450	-28 to 232
Braided PTFE	-20 to 500	-28 to 260
Graphite	-20 to 600	-28 to 315
PT	-20 to 450	-28 to 232
PTG	-20 to 450	-28 to 232
PTG XT	-20 to 550	-28 to 288

\*Body rating and packing temperature vs. pressure limits shall not be exceeded.

**BEARING/SHAFT CONFIGURATIONS (TABLE V)**

BEARING SPECIFICATIONS	MBT (1)	ULTIMET
<b>Configurations</b>	Standard	Optional
<b>Material</b>	UNS S 31600 / PTFE	UNS R 31233
<b>Shaft</b>	Standard	Standard
<b>Temperature Limits</b>	-20 to 425°F (-28 to 218°C)	-20 to 600°F (-28 to 315°C)
<b>Applications</b>	<ul style="list-style-type: none"> <li>■ General Service</li> <li>■ Special alloy valves</li> <li>■ Clean for O2 service</li> <li>■ NACE</li> </ul>	<ul style="list-style-type: none"> <li>■ Corrosive Service</li> <li>■ Clean for O2 service</li> </ul>

(1) MBT bearings are standard also for valves manufactured with special alloys such as Hastelloy-C, Monel, Titanium, Alloy 20.

## ROTARY ACTUATOR SERIES RA-XL (FIGURE 7)

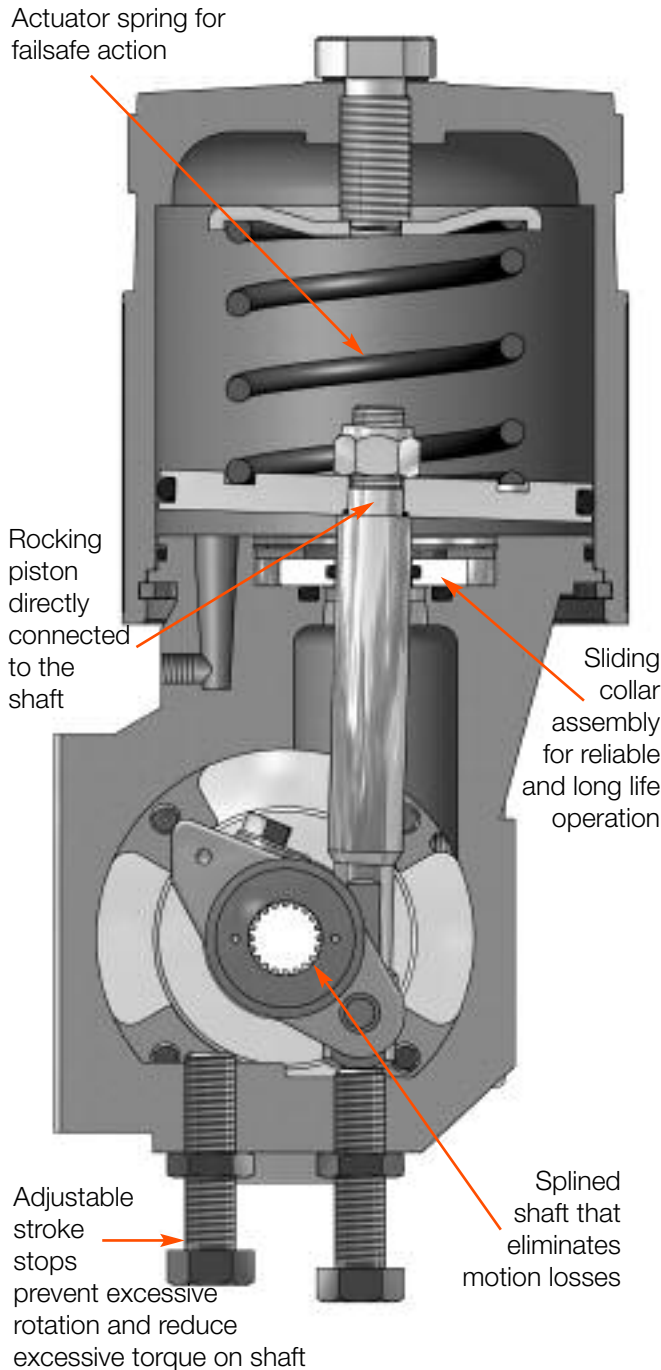

**High parts interchangeability -  
Reduces the need for spare parts**

**Lightweight and compact design -  
Helps handling and needs limited space**

## Actuators

The RA-XL spring-cylinder rotary actuator combines high torque and pneumatic stiffness with an excellent controllability. These characteristics are integrated into a single, rugged, lightweight and compact assembly, which makes it the ideal choice for rotary valves driving.

The RA-XL double acting spring-cylinder actuator is designed to operate with air supply pressures up to 150 psi (10.3 Bar), reaching high operating torques. The actuator Series RA-XL has a proven lifetime longer than a million of cycles, which makes it the most reliable actuator in the market. The double acting positioner feeds both cylinder chambers simultaneously, ensuring an exceptional stiffness. This pneumatic stiffness makes the actuator Series RA-XL insuperable when an accurate control of the valve positioning is required, even when the valve is operating at small openings.

These features enable a much better performance of the actuator Series RA-XL when compared with the spring-diaphragm type actuators.

### ACTUATOR SPECIFICATIONS (TABLE VI)

<b>Type</b>	<ul style="list-style-type: none"> <li>■ Double acting cylinder with positive spring for failsafe action</li> <li>■ Field reversible</li> </ul>
<b>Sizes</b>	25, 50, 100, 200
<b>Action</b>	<ul style="list-style-type: none"> <li>■ Air-to-Open</li> <li>■ Air-to-Close</li> <li>■ Fail-in-place</li> </ul>
<b>Air Supply Pressure</b>	Up to 150 psi maximum 10.3 Bar maximum
<b>Stroking Speed</b>	Aprox. 1 inch/sec.*
<b>Operating Temperature</b>	-40 to 350°F (-40 to 175°C)
<b>Auxiliary handwheel</b>	<ul style="list-style-type: none"> <li>■ Declutchable Side Assembly</li> <li>■ Manual, gear operated</li> <li>■ Lever</li> </ul>
<b>Positioners</b>	<ul style="list-style-type: none"> <li>■ HPP1500 Analog</li> <li>■ HPP3000 Digital</li> <li>■ HPP3500 Digital</li> </ul>

\* Sizes 25 and 50 with 60 psig air supply.



### MATERIALS OF CONSTRUCTION (TABLE VII)

<b>Yoke</b>	Ductile Iron
<b>Transfer Case</b>	Anodized Aluminum
<b>Splined Lever Arm</b>	Nickel Plated Ductile Iron
<b>Actuator Stem</b>	UNS S 41600 Stainless Steel
<b>Bearings</b>	Teflon reinforced with fiberglass filaments
<b>Sliding Collar</b>	Delrin®, Aluminum
<b>Cylinder Retaining Ring</b>	Zinc Plated steel
<b>Piston</b>	Anodized Aluminum
<b>Cylinder</b>	Anodized Aluminum
<b>O-rings*</b>	Buna N (Standard)
<b>Actuator Spring</b>	Steel (corrosion proof)
<b>Spring Button</b>	Carbon Steel

\* Room temperature higher than 180°F (82°C) require Viton o-rings.  
Temperatures lower than -40°F (-40°C) require Fluorsilicone o-rings.

### Positioners

FOR THROTTLING APPLICATIONS, THE ROTARY ACTUATORS SERIES RA-XL ALLOW THE USE OF SEVERAL POSITIONER OPTIONS.



#### DIGITAL HPP3500 SERIES (FIGURE 8)

This positioner has the same characteristics of HPP3000, 4-20 mA input signal and HART® protocol. This project was developed to make easier the positioner installation on rotary actuators with NAMUR interface. Intrinsically safe, this positioner is provided with NEMA 4X and IEC IP66 enclosure and can handle air supply pressures from 20 to 100 psig (1.4 to 6.9 Bar) at operating temperatures from -40 to 176°F (-40 - 80°C).

#### DIGITAL HPP3000 SERIES (FIGURE 9)

This is a high performance microprocessed positioner, compatible with HART®, DE and Fieldbus communication protocols or 4-20 mA analog signal, also programmable for several split range configuration. This positioner Series incorporates totally programmable functions such as: auto-tuning, manual and automatic modes, multiple communication protocols and diagnostic information, which contribute to increase productivity and efficiency of industrial plant operations and to lower maintenance. The digital positioner Series HPP3000 can handle air supply pressures from 20 to 100 psig (1.4 to 6.9 Bar) at operating temperatures from -40 to 176°F (-40 to 80°C).

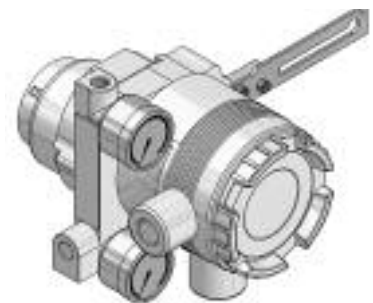

#### ANALOG HPP1500 SERIES (FIGURE 10)

This is a single or double acting high performance positioner. It allows the use of a pneumatic module for pneumatic input signals or an analog electro-pneumatic module for control signals in milliamps. Highly resistant and using the state-of-the-art technology, it works with air supply pressures up to 150 psig (10.3 Bar) without requiring air pressure regulators and withstands ambient temperatures from -40 to 176°F (-40 to 80°C). The positioner Series HPP1500 allows two or three split-range configurations with the use of a specific cam.

# MATERIALS OF CONSTRUCTION

**STANDARD MATERIALS OF CONSTRUCTION  
CARBON STEEL SUB-ASSEMBLY (TABLE VIII)**

ITEM	MATERIAL CLASSIFICATION	SPECIFICATION		
		ASTM CODE (AMS No.)	UNS CODE	HARDNESS R <sub>c</sub>
<b>Body</b>	Carbon Steel (Casting)	A 216 Gr WCB	J 03002	
<b>Disc</b>	316 (Casting), Chrome Plated	A 351 Gr CF8M	J 92900	
<b>Shaft / Pins</b>	17-4 PH (Bar)	A 564 Gr 630	S 17400	35
<b>Shaft Flange</b>	Carbon steel (Bar or plate)	AMS 5086B		
<b>Bearings</b>	MBT	A 479 Gr 316 / PTFE	S 31600	
	Ultimet	B 818	R 31233	30
<b>Soft Seat Retainer</b>	316 (Bar or plate)	A 479 Gr 316	S 31600	
<b>Metal Seat</b>	316 (Bar or plate)	A 479 Gr 316	S 31600	
<b>Soft Seat</b>	PTFE			
	PTFEG			
	PEEK			
<b>Gland Flange</b>	316 (Casting)	A 351 Gr CF8M	J 92900	
<b>Packing Follower</b>	316 (Bar)	A 479 Gr 316	S 31600	
<b>Packing Spacers</b>	316 (Bar)	A 479 Gr 316	S 31600	

**STANDARD MATERIALS OF CONSTRUCTION  
STAINLESS STEEL SUB-ASSEMBLY (TABLE IX)**

ITEM	MATERIAL CLASSIFICATION	SPECIFICATION		
		ASTM CODE (AMS No.)	UNS CODE	HARDNESS R <sub>c</sub>
<b>Body</b>	316 (Casting)	A 351 Gr CF8M	J 92900	
<b>Disc</b>	316 (Casting), Chrome Plated	A 351 Gr CF8M	J 92900	
<b>Shaft / Pins</b>	17-4 PH (Bar)	A 564 Gr 630	S 17400	35
<b>Shaft flange</b>	316 (Bar or plate)	A 479 Gr 316	S 31600	
<b>Bearings</b>	MBT	A 479 Gr 316 / PTFE	S 31600	
	Ultimet	B 818	R 31233	30
<b>Soft Seat Retainer</b>	316 (Bar or plate)	A 479 Gr 316	S 31600	
<b>Metal Seat</b>	316 (Bar or plate)	A 479 Gr 316	S 31600	
<b>Soft Seat</b>	PTFE			
	PTFEG			
	PEEK			
<b>Gland Flange</b>	316 (Casting)	A 351 Gr CF8M	J 92900	
<b>Packing Follower</b>	316 (Bar)	A 479 Gr 316	S 31600	
<b>Packing Spacers</b>	316 (Bar)	A 479 Gr 316	S 31600	



# MATERIALS

**PRESSURE AND TEMPERATURE LIMITS FOR  
VALVE BODIES – ANSI B 16.34 (TABLE X)**

MATERIAL	CLASS	PRESSURE		TEMPERATURE	
		PSI	BAR	°F	°C
<b>Carbon Steel ASTM A 216 Gr. WCB</b>	<b>ANSI 150</b>	285	19.7	-20 to 100	-29 to 38
		260	17.9	200	93
		230	15.9	300	149
		200	13.8	400	204
		170	11.7	500	260
		140	9.7	600	316
	<b>ANSI 300</b>	740	51.0	-20 to 100	-29 to 38
		675	46.5	200	93
		655	45.2	300	149
		635	43.8	400	204
		600	41.4	500	260
		550	37.9	600	316
<b>Stainless Steel ASTM A 351 Gr. CF8M</b>	<b>ANSI 150</b>	275	19.0	-20 to 100	-29 to 38
		235	16.2	200	93
		215	14.8	300	149
		195	13.4	400	204
		170	11.7	500	260
		140	9.7	600	316
	<b>ANSI 300</b>	720	49.7	-20 to 100	-29 to 38
		620	42.8	200	93
		560	39.4	300	149
		515	35.5	400	204
		480	33.1	500	260
		450	31.0	600	316

# MATERIALS / SPECIFICATIONS

**OPTIONAL MATERIALS OF CONSTRUCTION (TABLE XI)**

Material	304	304L	316L	Monel	Alloy 20	Hastelloy C	Hast. B/B2	Titanium
ASTM	A351 CF8	A351 CF3	A351 CF3M	A494 M35-1	A351 CN 7M	A494-CW6M	A494 N-7M-1	B367 Gr. 3
Body	304	304L	316L	Monel 400	Alloy 20	Hastelloy C	Hast. B/B2	Titanium
Disc	304, Chrome Plated	304L, Chrome Plated	316L, Chrome Plated	Monel 400	Alloy 20	Hastelloy C	Hast. B/B2	Titanium
Shaft & pins	17-4PH	17-4PH	17-4PH	K-Monel	Alloy 20	Hastelloy C	Hast. B/B2	Titanium
Shaft Flange	304	304L	316L	Monel 400	Alloy 20	Hastelloy C	Hast. B/B2	Titanium
Seat Ring	304 / PTFE	304L / PTFE	316L / PTFE	PTFE	PTFE	PTFE	PTFE	PTFE
Seat Retainer	304	304L	316L	Monel 400	Alloy 20	Hastelloy C	Hast. B/B2	Titanium
Bearings	MBT	MBT	MBT	MBT	MBT	MBT	MBT	MBT

**MAXIMUM ALLOWABLE PRESSURE DROP - SHAFT (TABLE XII) \***

Shaft Material: 17-4 PH

Temperature F (°C)	Valve Size (inches)						
	2	3	4	6	8	10	12
	Upstream or Downstream Flow – Psi (Bar)						
-50 (-45)	725 (50.0)	725 (50.0)	725 (50.0)	725 (50.0)	700 (48.2)	725 (50.0)	725 (50.0)
70 (21)	725 (50.0)	725 (50.0)	725 (50.0)	725 (50.0)	700 (48.2)	725 (50.0)	725 (50.0)
200 (93)	725 (50.0)	725 (50.0)	725 (50.0)	725 (50.0)	675 (46.5)	720 (49.6)	725 (50.0)
300 (149)	725 (50.0)	725 (50.0)	725 (50.0)	725 (50.0)	645 (44.5)	690 (47.6)	700 (48.2)
400 (204)	725 (50.0)	725 (50.0)	725 (50.0)	725 (50.0)	610 (42.0)	650 (44.8)	665 (45.9)
425 (218)	725 (50.0)	725 (50.0)	725 (50.0)	725 (50.0)	605 (41.7)	640 (44.1)	650 (44.8)
600 (315)	725 (50.0)	725 (50.0)	725 (50.0)	710 (49.0)	550 (37.9)	590 (40.7)	600 (41.4)

\*Body rating shall not be exceeded.

**MAXIMUM ALLOWABLE PRESSURE DROP - SEATS (TABLE XIII) \***

**SEAT MATERIAL: VIRGIN PTFE**

Temperature °F (°C)	Valve Size (inches)						
	2	3	4	6	8	10	12
	Upstream or Downstream Flow – Psi (Bar)						
-50 (-45)	720 (49.6)	720 (49.6)	720 (49.6)	720 (49.6)	720 (49.6)	720 (49.6)	720 (49.6)
70 (21)	720 (49.6)	720 (49.6)	720 (49.6)	720 (49.6)	720 (49.6)	720 (49.6)	720 (49.6)
200 (93)	430 (29.6)	430 (29.6)	430 (29.6)	430 (29.6)	430 (29.6)	430 (29.6)	430 (29.6)
300 (149)	140 (9.6)	140 (9.6)	140 (9.6)	140 (9.6)	140 (9.6)	140 (9.6)	140 (9.6)

**SEAT MATERIAL: GLASS FILLED PTFE (PTFEG)**

Temperature °F (°C)	Valve Size (inches)						
	2	3	4	6	8	10	12
	Upstream or Downstream Flow – Psi (Bar)						
-50 (-45)	725 (50.0)	725 (50.0)	725 (50.0)	725 (50.0)	725 (50.0)	725 (50.0)	725 (50.0)
70 (21)	725 (50.0)	725 (50.0)	725 (50.0)	725 (50.0)	725 (50.0)	725 (50.0)	725 (50.0)
200 (93)	720 (49.6)	720 (49.6)	720 (49.6)	720 (49.6)	720 (49.6)	720 (49.6)	720 (49.6)
300 (149)	400 (27.6)	400 (27.6)	400 (27.6)	400 (27.6)	400 (27.6)	400 (27.6)	400 (27.6)
400 (204)	80 (5.5)	80 (5.5)	80 (5.5)	80 (5.5)	80 (5.5)	80 (5.5)	80 (5.5)

**SEAT MATERIAL: 316 STAINLESS STEEL**

Temperature °F (°C)	Valve Size (inches)						
	2	3	4	6	8	10	12
	Upstream Flow – Psi (Bar)						
-50 (-45)	260 (17.9)	260 (17.9)	260 (17.9)	260 (17.9)	260 (17.9)	260 (17.9)	260 (17.9)
70 (21)	260 (17.9)	260 (17.9)	260 (17.9)	260 (17.9)	260 (17.9)	260 (17.9)	260 (17.9)
200 (93)	260 (17.9)	260 (17.9)	260 (17.9)	260 (17.9)	260 (17.9)	260 (17.9)	260 (17.9)
300 (149)	250 (17.2)	250 (17.2)	250 (17.2)	250 (17.2)	250 (17.2)	250 (17.2)	250 (17.2)
400 (204)	230 (15.9)	230 (15.9)	230 (15.9)	230 (15.9)	230 (15.9)	230 (15.9)	230 (15.9)
425 (218)	220 (15.2)	220 (15.2)	220 (15.2)	220 (15.2)	220 (15.2)	220 (15.2)	220 (15.2)
600 (315)	180 (12.4)	180 (12.4)	180 (12.4)	180 (12.4)	180 (12.4)	180 (12.4)	180 (12.4)

Temperature °F (°C)	Valve Size (inches)						
	2	3	4	6	8	10	12
	Downstream Flow – Psi (Bar)						
-50 (-45)	725 (50.0)	725 (50.0)	725 (50.0)	725 (50.0)	725 (50.0)	725 (50.0)	725 (50.0)
70 (21)	725 (50.0)	725 (50.0)	725 (50.0)	725 (50.0)	725 (50.0)	725 (50.0)	725 (50.0)
200 (93)	725 (50.0)	725 (50.0)	725 (50.0)	725 (50.0)	725 (50.0)	725 (50.0)	725 (50.0)
300 (149)	725 (50.0)	725 (50.0)	725 (50.0)	725 (50.0)	725 (50.0)	725 (50.0)	725 (50.0)
400 (204)	725 (50.0)	725 (50.0)	725 (50.0)	725 (50.0)	725 (50.0)	725 (50.0)	725 (50.0)
425 (218)	725 (50.0)	725 (50.0)	725 (50.0)	725 (50.0)	725 (50.0)	725 (50.0)	725 (50.0)
600 (315)	600 (41.4)	600 (41.4)	600 (41.4)	600 (41.4)	600 (41.4)	600 (41.4)	600 (41.4)

\*Body rating shall not be exceeded.

# MATERIALS / SPECIFICATIONS

## MAXIMUM ALLOWABLE PRESSURE DROP – BEARINGS (TABLE XIV)\*

### BEARINGS MATERIAL: MBT

Temperature F (°C)	Valve Size (inches)						
	2	3	4	6	8	10	12
	Upstream or Downstream Flow – Psi (Bar)						
-50 (-45)	725 (50.0)	725 (50.0)	725 (50.0)	725 (50.0)	725 (50.0)	725 (50.0)	725 (50.0)
70 (21)	725 (50.0)	725 (50.0)	725 (50.0)	725 (50.0)	725 (50.0)	725 (50.0)	725 (50.0)
200 (93)	600 (41.3)	600 (41.3)	600 (41.3)	600 (41.3)	600 (41.3)	600 (41.3)	600 (41.3)
300 (149)	490 (33.7)	490 (33.7)	490 (33.7)	490 (33.7)	490 (33.7)	490 (33.7)	490 (33.7)
400 (204)	375 (25.8)	375 (25.8)	375 (25.8)	375 (25.8)	375 (25.8)	375 (25.8)	375 (25.8)
425 (218)	350 (24.1)	350 (24.1)	350 (24.1)	350 (24.1)	350 (24.1)	350 (24.1)	350 (24.1)

### BEARINGS MATERIAL: ULTIMET

Temperature F (°C)	Valve Size (inches)						
	2	3	4	6	8	10	12
	Upstream or Downstream Flow – Psi (Bar)						
-50 (-45)	725 (50.0)	725 (50.0)	725 (50.0)	725 (50.0)	725 (50.0)	725 (50.0)	725 (50.0)
70 (21)	725 (50.0)	725 (50.0)	725 (50.0)	725 (50.0)	725 (50.0)	725 (50.0)	725 (50.0)
200 (93)	725 (50.0)	725 (50.0)	725 (50.0)	725 (50.0)	725 (50.0)	725 (50.0)	725 (50.0)
300 (149)	725 (50.0)	725 (50.0)	725 (50.0)	725 (50.0)	725 (50.0)	725 (50.0)	725 (50.0)
400 (204)	725 (50.0)	725 (50.0)	725 (50.0)	725 (50.0)	725 (50.0)	725 (50.0)	725 (50.0)
425 (218)	725 (50.0)	725 (50.0)	725 (50.0)	725 (50.0)	725 (50.0)	725 (50.0)	725 (50.0)
600 (315)	725 (50.0)	725 (50.0)	725 (50.0)	725 (50.0)	725 (50.0)	725 (50.0)	725 (50.0)

\*Body rating shall not be exceeded.

## MAXIMUM ALLOWABLE PRESSURE DROP (1)(2)(3) ACTUATOR SIZE VS. SUPPLY PRESSURE – PSI/BAR (TABLE XV)

Valve Size (inches)	Failure Position	Actuator Size																		
		25						50						100						
		Air Supply Pressure																		
		PSI	Bar	PSI	Bar	PSI	Bar	PSI	Bar	PSI	Bar	PSI	Bar	PSI	Bar	PSI	Bar	PSI	Bar	
2	OPEN	725	50.0	725	50.0	725	50.0	725	50.0	725	50.0	725	50.0							
	CLOSED	725	50.0	725	50.0	725	50.0	725	50.0	725	50.0	725	50.0							
3	OPEN	725	50.0	725	50.0	725	50.0	725	50.0	725	50.0	725	50.0							
	CLOSED	380	26.2	380	26.2	380	26.2	725	50.0	725	50.0	725	50.0							
4	OPEN	71	4.9	725	50.0	725	50.0	725	50.0	725	50.0	725	50.0							
	CLOSED	88	6.0	88	6.0	88	6.0	545	37.6	545	37.6	545	37.6							
6	OPEN							725	50.0	725	50.0	725	50.0	725	50.0	725	50.0	725	50.0	
	CLOSED							103	7.1	103	7.1	103	7.1	725	50.0	725	50.0	725	50.0	
8	OPEN							190	13.1	451	31.1	712	49.1	725	50.0	725	50.0	725	50.0	
	CLOSED							N/A	N/A	N/A	N/A	N/A	N/A	N/A	N/A	582	40.1	582	40.1	
10	OPEN							43	2.9	202	13.9	361	24.9	634	43.7	725	50.0	725	50.0	
	CLOSED							N/A	N/A	N/A	N/A	N/A	N/A	N/A	N/A	282	19.4	282	19.4	
12	OPEN														257	17.7	257	17.7	305	21.0
	CLOSED														N/A	N/A	137	9.4	137	9.4

(1) With shaft downstream and PTFE standard packing. (2) Body rating shall not be exceeded, as well the pressure/temperature limits of shaft, seats and bearings. (3) For throttling applications, the actuator stiffness and the opening angle shall be considered.

# PACKINGS

THE BXL® PACKING BOX HAS A LARGE DEPTH AND AN EXCELLENT FINISH OF INTERNAL SURFACES, WHICH PROVIDES A LONGER OPERATING LIFE FOR THE WHOLE PACKING SET. DUE TO ITS DESIGN CHARACTERISTICS, THE BXL® PACKING BOX ALLOWS THE USE OF A LARGE VARIETY OF PACKING SYSTEMS FOR A BETTER COMPLIANCE WITH THE MOST STRINGENT STANDARDS CONCERNING FUGITIVE EMISSION CONTROL IN MODERN INDUSTRIAL PROCESSES.

## STANDARD PACKING (FIGURE 11)

The standard packing of BXL® valves is comprised by PTFE “V” Rings. The PTFE “V” Rings have been the most largely used packing material for many years, with excellent tightness results. Its low friction characteristics, good mechanical strength and excellent corrosion resistance make it the most commonly used material for stem and shaft sealing. The PTFE “V” rings are used in the BXL® valve with operating temperatures from -20 to 450°F (-28 to 232°C).

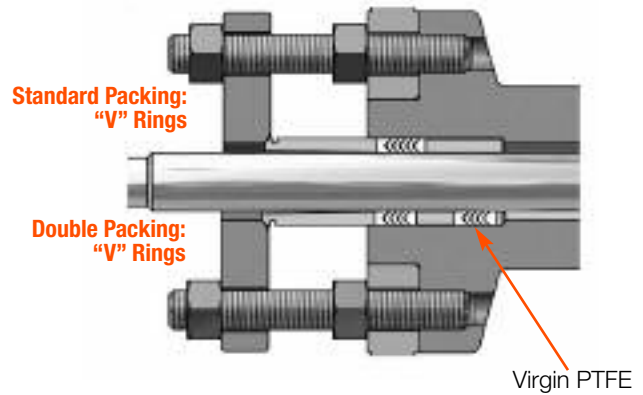

## HIGH TEMPERATURE PACKING (FIGURE 12)

The BXL® packing with molded rings is an option when the operating temperature exceeds the limits of PTFE “V” rings. The materials used for BXL® molded packings are braided PTFE for operating temperatures up to 500°F (260°C) and graphite for operating temperatures up to 600°F (315°C). The graphite molded rings packing is an excellent solution for high temperature applications. However, the high force required for its sealing causes a considerably friction increase in the valve rotation.

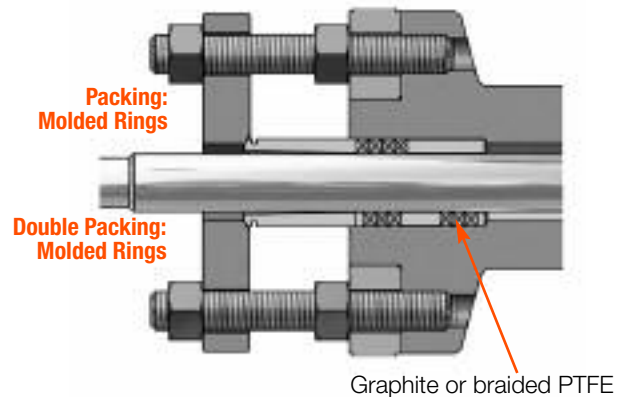

## SPECIAL PACKINGS (FIGURE 13)

The PT packing type is comprised by a “V” rings set, uniformly and constantly compressed by a mechanical device which includes pairs of belleville washers that acts as springs and provides a “live load” effect. This system reaches a tightness level below 500 ppm. The PT packing type combines the superior quality of virgin PTFE rings with carbon filled PTFE rings. The PTG packing type is comprised by an advanced set of rings able to maintain levels of emission much lower than 500 ppm (usually 10 ppm). The PTG packing combines carbon filled PTFE “V” rings with Kalrez “V” rings, an advanced material which provides a superior packing performance. The PTG XT packing type is used for higher temperatures, up to 550°F (288°C). It uses Zymax “V” rings replacing the carbon filled PTFE rings.

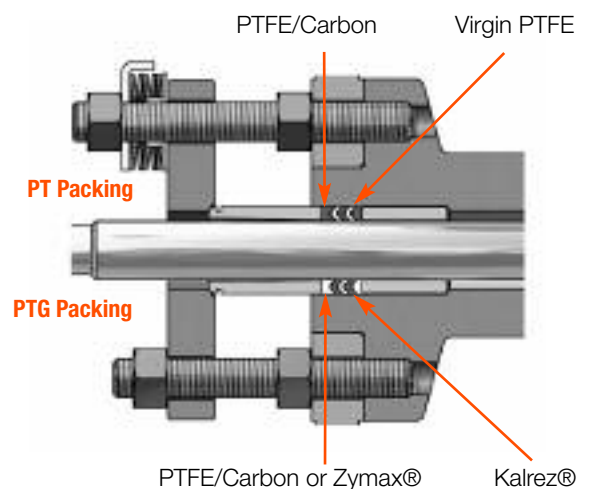

# FLOW COEFFICIENTS

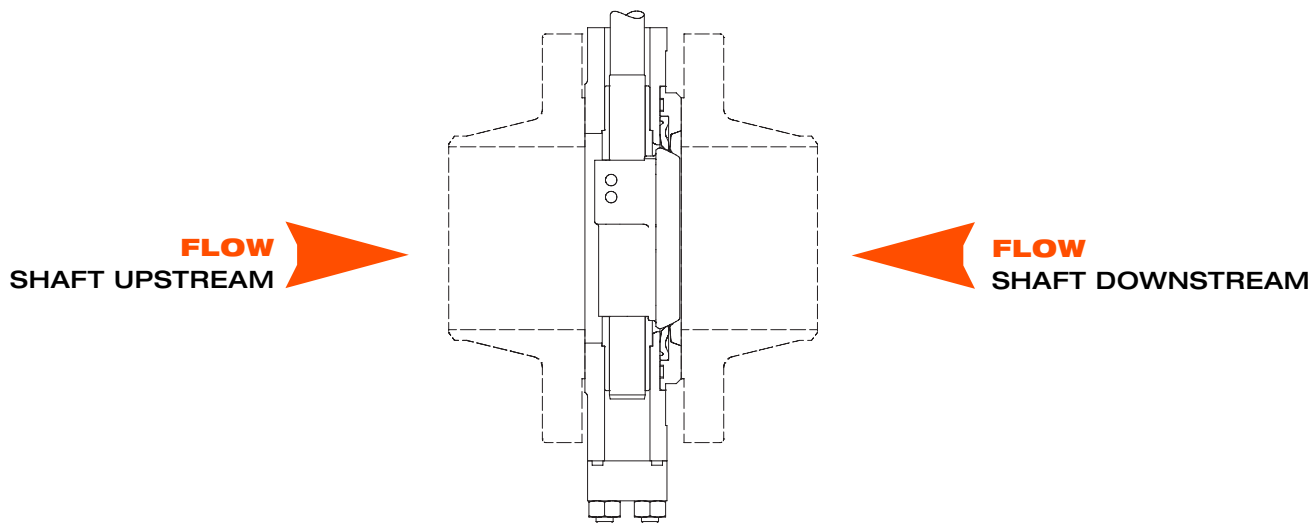

**FLOW COEFFICIENTS ( $C_V$ ) - SHAFT DOWNSTREAM (TABLE XVI)**

Valve Size (inches)	Opening Angle (degrees)								
	90	80	70	60	50	40	30	20	10
2	50	51	52	51	46	37	24	11.0	2.8
3	122	123	118	113	105	88	62	34	10.9
4	242	250	225	196	181	152	103	54	13.9
6	973	899	705	531	390	257	169	94	33
8	1564	1488	1177	928	717	522	347	191	65
10	2638	2374	1923	1467	1093	752	433	226	67
12	3865	3520	2838	2220	1691	1178	765	444	203

**FLOW COEFFICIENTS ( $C_V$ ) - SHAFT UPSTREAM (TABLE XVII)**

Valve Size (inches)	Opening Angle (degrees)								
	90	80	70	60	50	40	30	20	10
2	54	58	59	55	49	41	25	11.5	2.9
3	134	135	128	125	112	88	58	32	10.4
4	347	342	320	302	265	201	130	64	19.8
6	871	746	617	498	377	247	160	92	33
8	1645	1501	1198	962	717	495	317	184	66
10	2782	2576	2086	1620	1200	811	512	287	116
12	4005	3771	3104	2441	1852	1271	781	426	176



# DIMENSIONS - VALVE WITH ACTUATOR AND HPP1500 POSITIONER

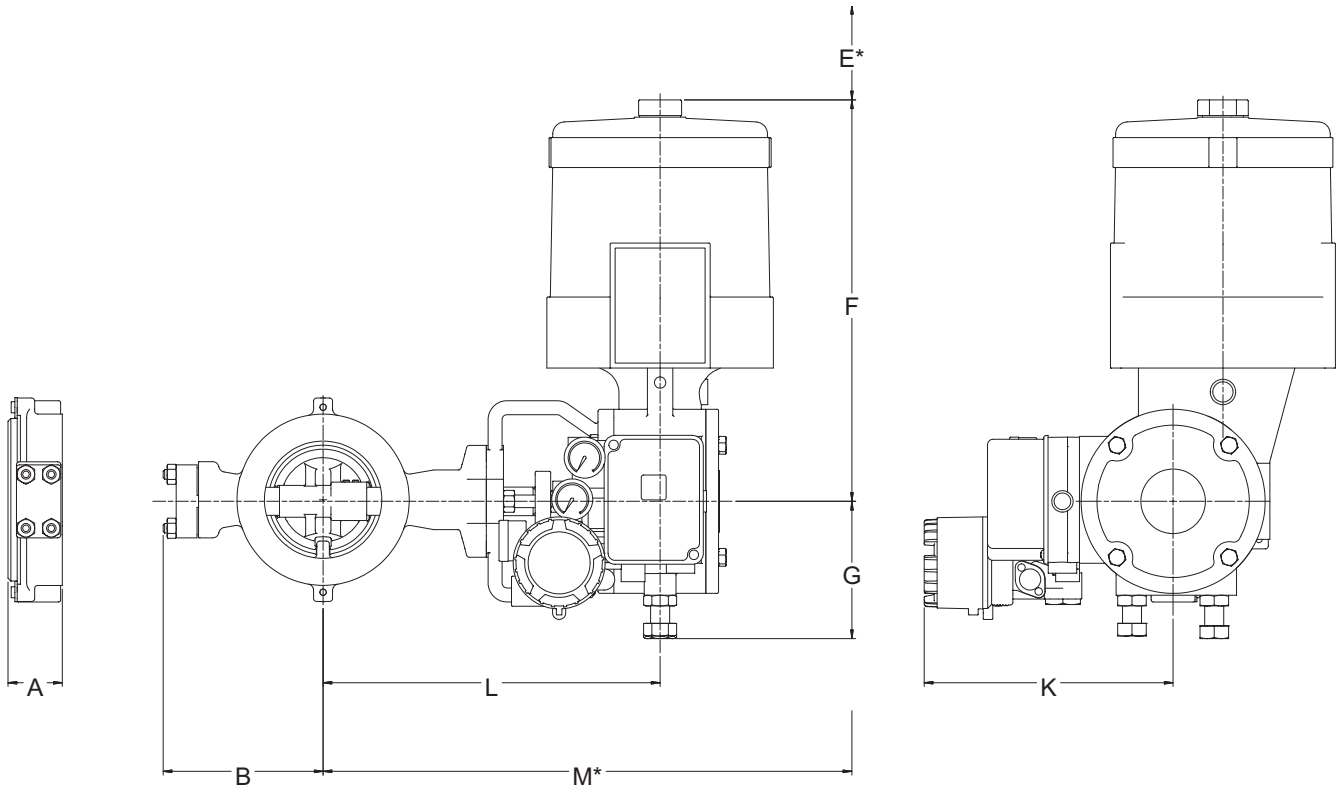

## DIMENSION A: FACE-TO-FACE DIMENSION

**DIMENSIONS (TABLE XVIII)**

Valve Size (inches)	ANSI Class	Actuator size	A		B		E*		F		G		K**		L		M*	
			Inches	mm	Inches	mm	Inches	mm	Inches	mm	Inches	mm	Inches	mm	Inches	mm	Inches	mm
2	150-300	25	1.8	44	5.3	135	6.0	152	13.2	335	4.6	116	8.9	227	11.7	298	18.7	475
	150-300	50	1.8	44	5.3	135	8.0	203	18.3	465	5.6	144	9.8	250	11.7	298	19.5	495
3	150-300	25	1.9	48	6.1	155	6.0	152	13.2	335	4.6	116	8.9	227	12.1	308	19.1	485
	150-300	50	1.9	48	6.1	155	8.0	203	18.3	465	5.6	144	9.8	250	12.1	308	19.9	505
4	150-300	25	2.1	54	6.9	176	6.0	152	13.2	335	4.6	116	8.9	227	12.8	325	19.8	503
	150-300	50	2.1	54	6.9	176	8.0	203	18.3	465	5.6	144	9.8	250	12.8	325	20.6	523
6	150-300	50	2.3	57	8.5	217	8.0	203	18.3	465	5.6	144	9.8	250	14.7	373	22.5	571
	150-300	100	2.3	57	8.5	217	11.0	279	22.6	575	7.0	179	10.9	276	14.7	373	24.9	632
8	150-300	50	2.5	64	9.6	244	8.0	203	18.3	465	5.6	144	9.8	250	16.7	425	24.5	622
	150-300	100	2.5	64	9.6	244	11.0	279	22.6	575	7.0	179	10.9	276	16.7	425	26.9	683
10	150-300	50	2.8	71	10.7	271	8.0	203	18.3	465	5.6	144	9.8	250	17.9	454	25.6	650
	150-300	100	2.8	71	10.7	271	11.0	279	22.6	575	7.0	179	10.9	276	17.9	454	28.1	714
12	150-300	100	3.2	81	12.1	308	11.0	279	22.6	575	7.0	179	10.9	276	19.1	484	29.3	744

\* Clearances required for actuator disassembly. \*\* For HPP1500 pneumatic positioner, deduct 2.40 inches (61 mm) from the dimension "K".

# ACTUATOR - MOUNTING ORIENTATIONS

## STANDARD RIGHT HAND MOUNTING – SHAFT UPSTREAM

MOUNTING A

AIR-TO-CLOSE: **FAIL-OPEN**

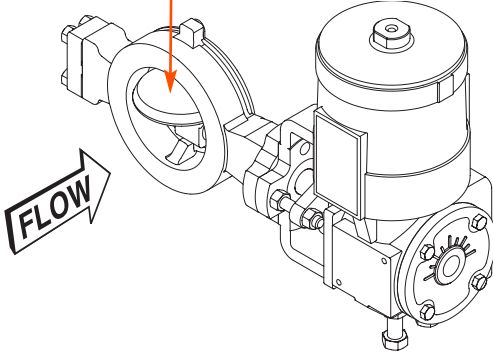

MOUNTING B

AIR-TO-OPEN: **FAIL-CLOSE**

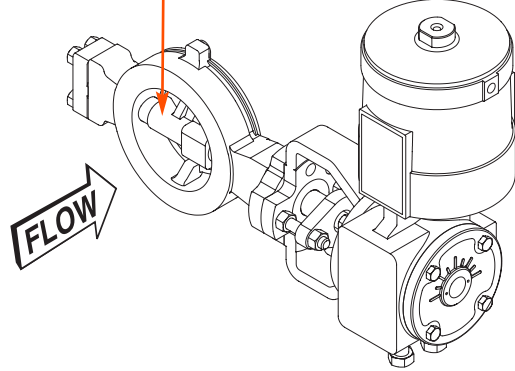

## STANDARD LEFT HAND MOUNTING – SHAFT DOWNSTREAM

MOUNTING C

AIR-TO-CLOSE: **FAIL-OPEN**

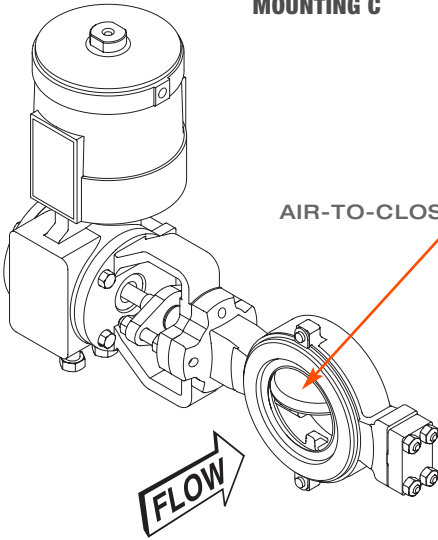

MOUNTING D

AIR-TO-OPEN: **FAIL-CLOSE**

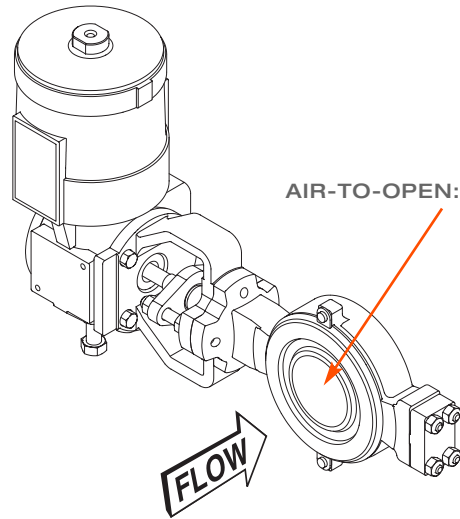

Quality Management System



**ISO 9001-2000**

Certificate No. 311001 QM

The information and specification contained in this bulletin are considered accurate. However, they are provided only for information purposes and should not be considered as certified. Valtek Sulamericana products are continuously improved and upgraded, so the specification, dimensions and information contained herein are subject to change without notice. For further information or to confirm these presented here, contact your Valtek Sulamericana representative. Specific instructions for installation, operation and maintenance of the BXL control valve are contained in Maintenance Bulletin n° 37.

Teflon, Kalrez, Zymax and Delrin are registered trademarks of E.I. DuPont Company. Ultemet is a trademark of Haynes, Int. HART is a registered trademark of HART Communication Foundation.

Printed in Brazil

[www.valteksulamericana.com.br](http://www.valteksulamericana.com.br)

Cat. Valtek Sulamericana BXL Rev. 0 10/2006E PN-9897002